

# Wall Mounted Basin Installation Instruction

Remark: apply to all similar wall mounted basins

Product and installation components:

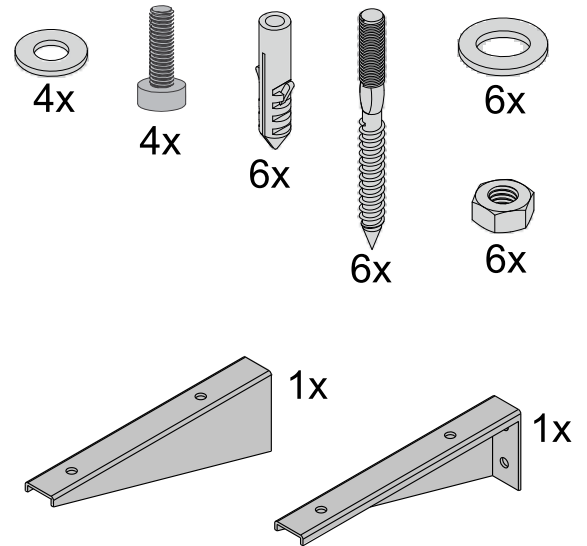
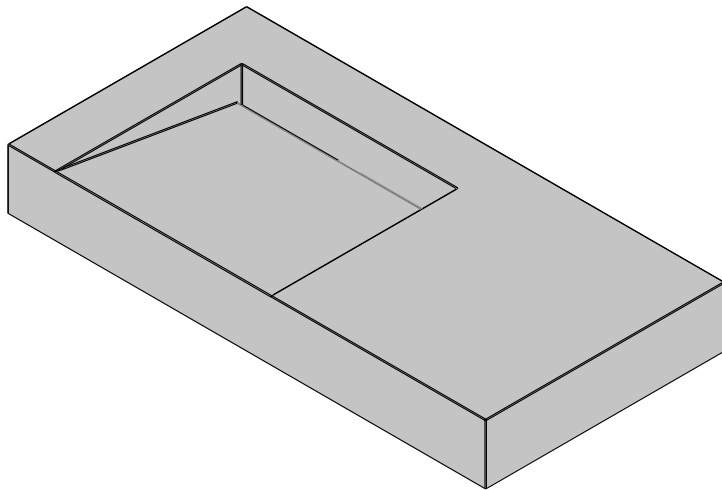

Installation tools:

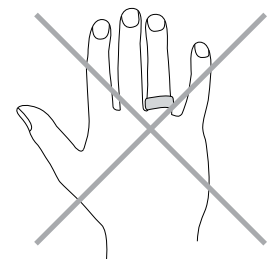
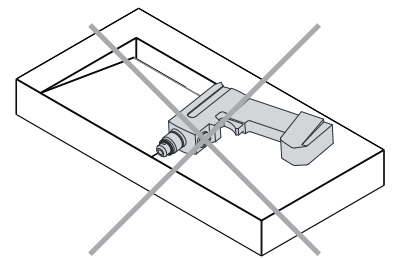
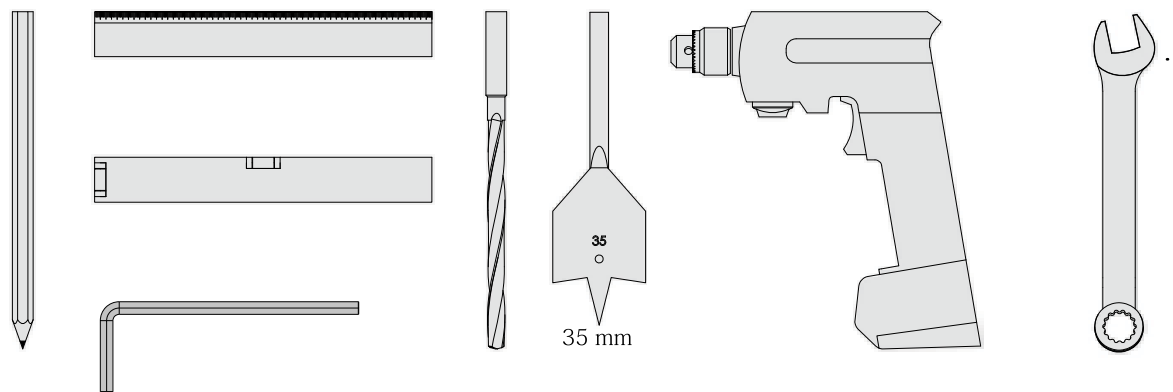

Note:

1. During installation one has to prevent damaging the surface of the product due to placing hard objects on the product.
2. installer should take off the rings etc. on the hand to avoid damage the product.

# 1\_

Drill the tap holes with a spade bit ( $\text{\O}35\text{mm}$ ).  
If no tap hole please ignore.

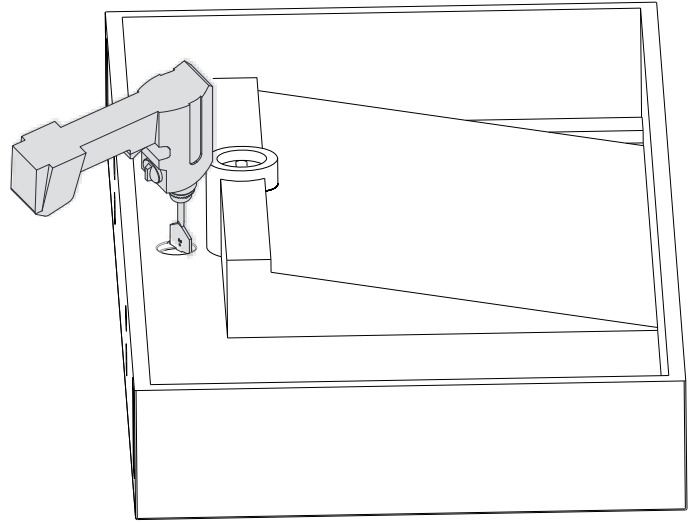

---

# 2\_

Draw a central line on the wall according to the basin.

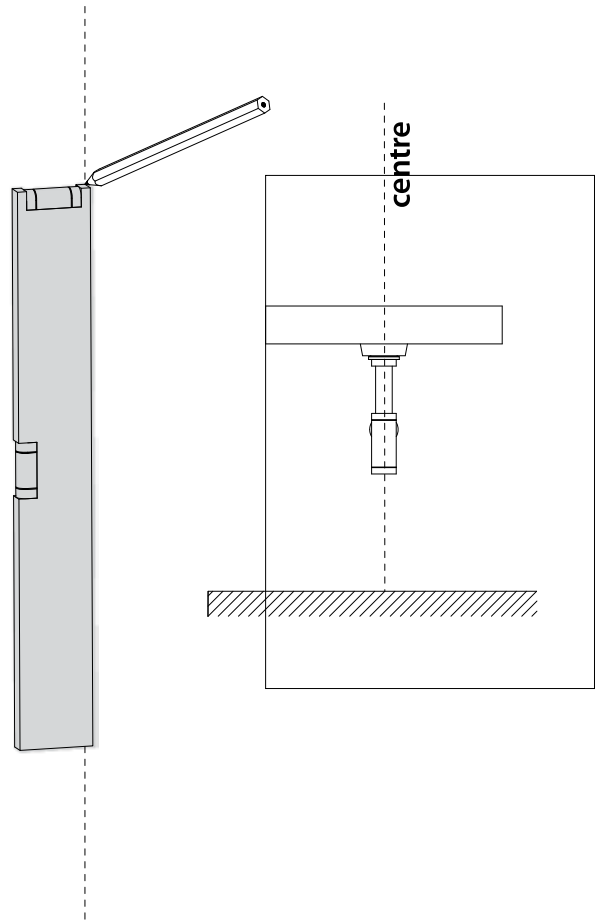

3\_

Mark the mounting position on the wall.

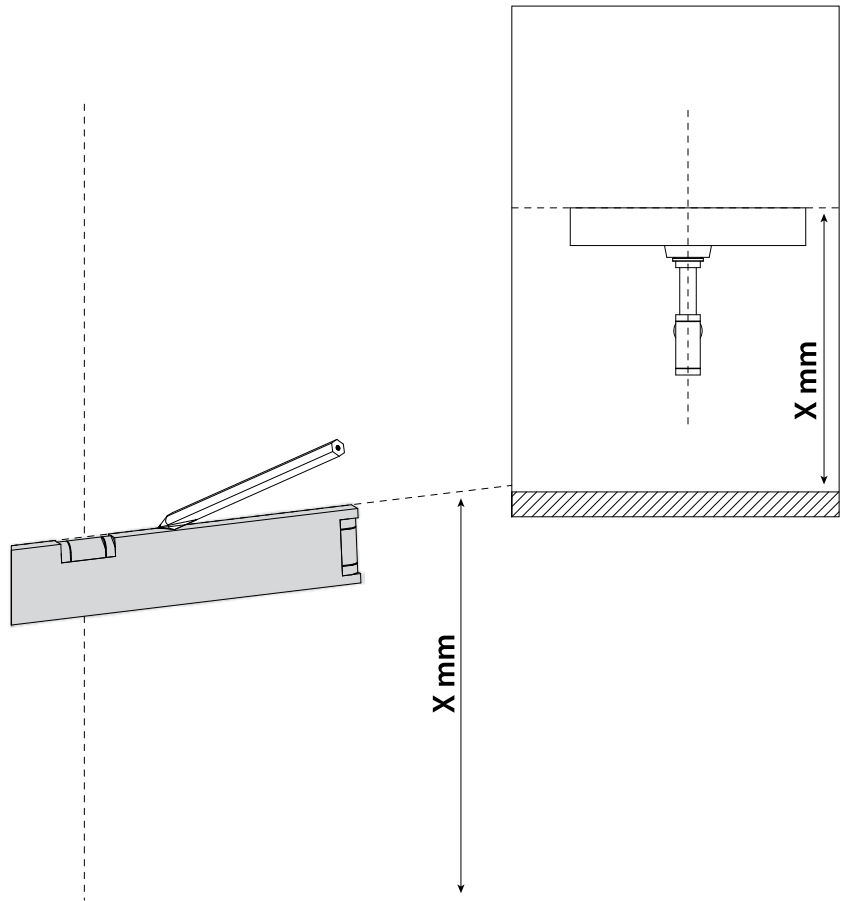

4\_

Mark the mounting hole positions on the wall according to the basin mounting holes.

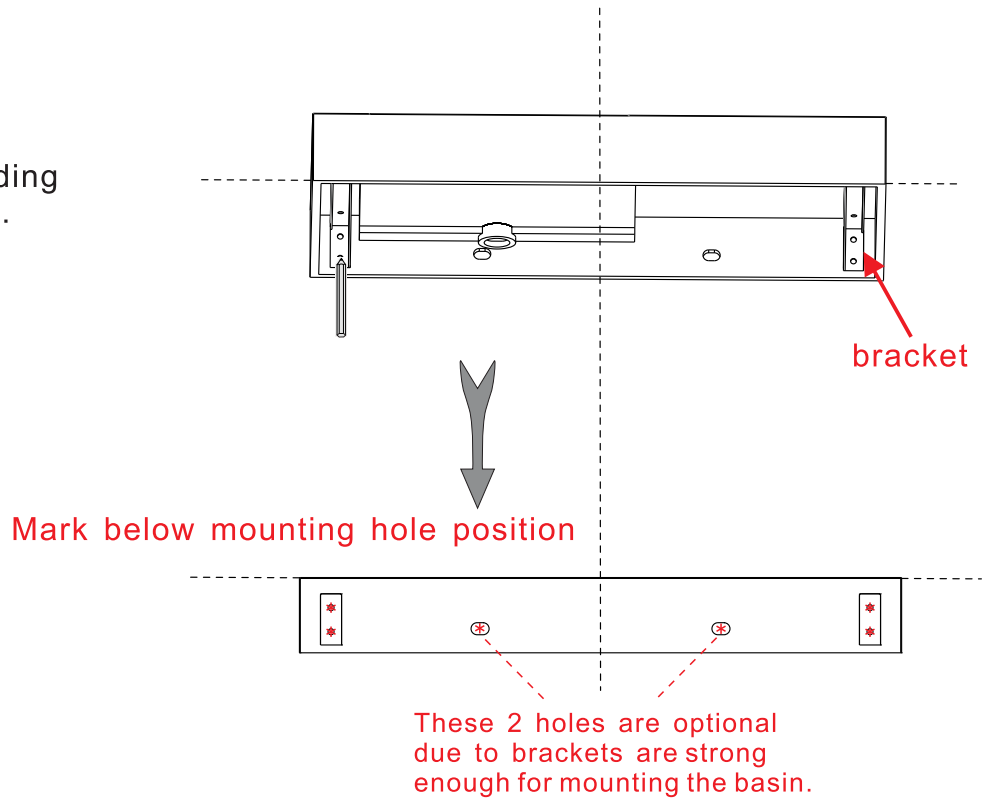

\* — mounting holes position

# 5\_

Drill the hole  $\varnothing 12\text{mm}$ .

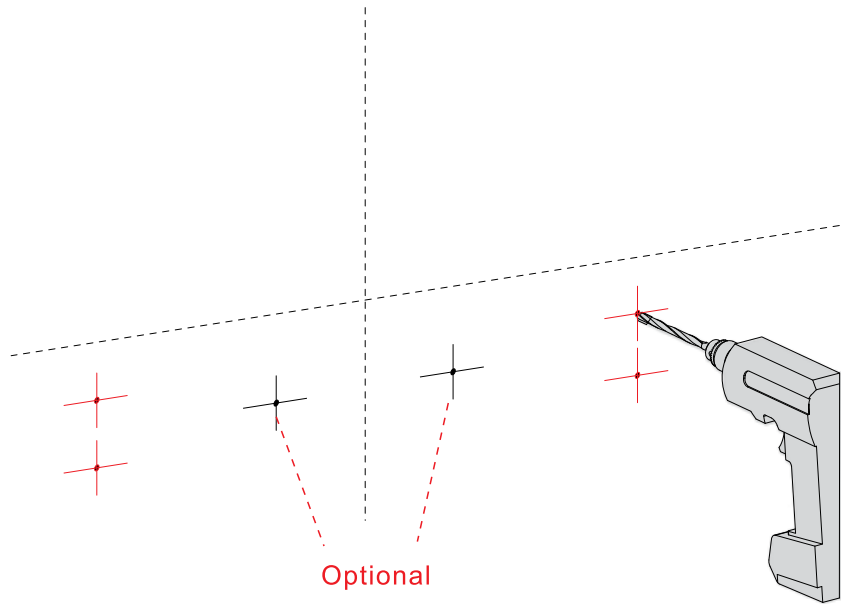

---

# 6\_

Insert the dowels into the holes and screw the dowel screws in the dowels.

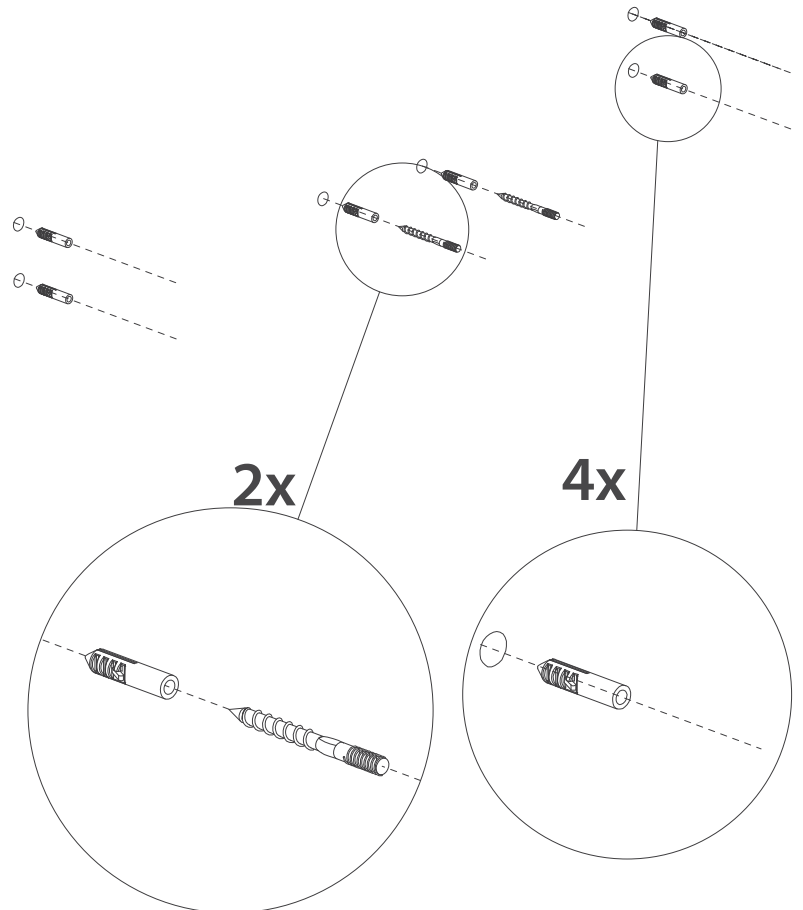

7\_

fix the brackets onto the wall;

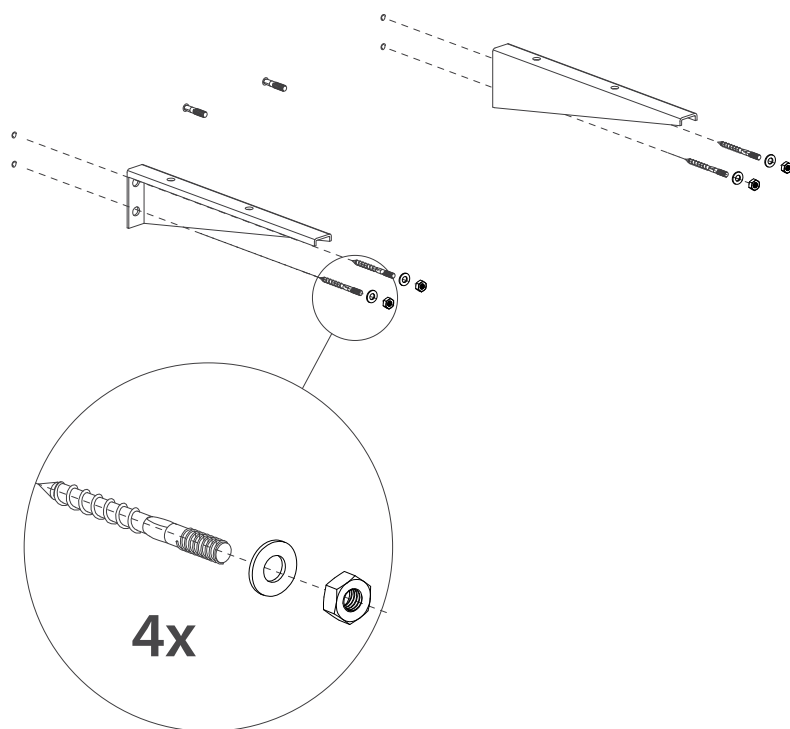

8\_

Place the washbasin on the dowel screws,  
fasten the nuts to fix the basin.

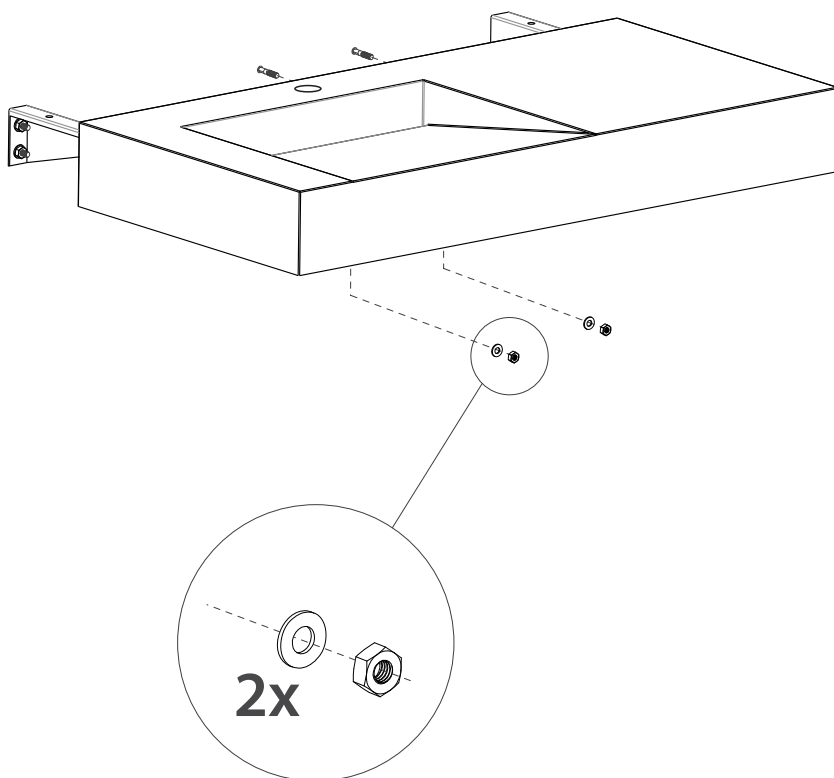

9\_

install the basin onto the brackets by washers and nuts. Adjust the level by level ruler.

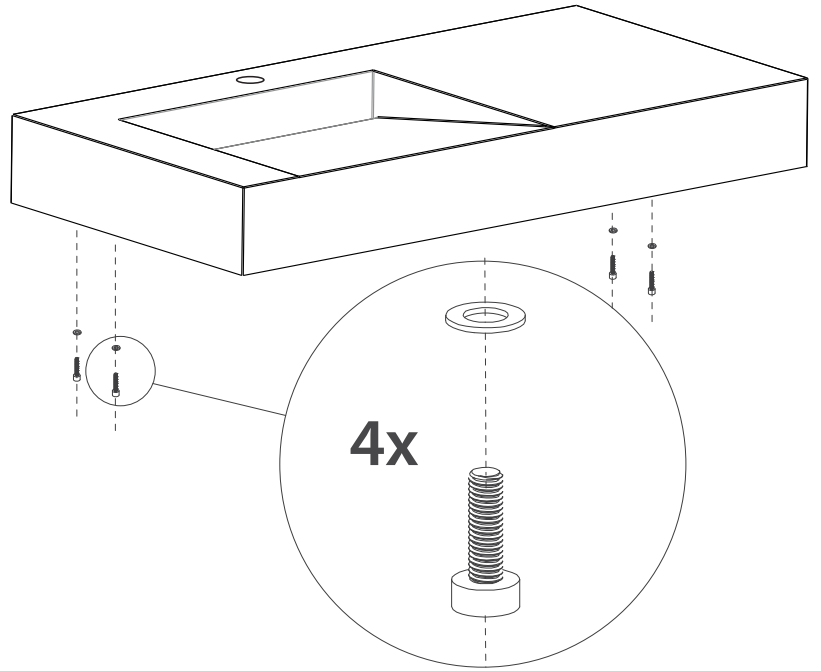

## Finished

Go on other installation such as taps and drain...

